

GEZE SECULOGIC TZ 300

Emergency Exit System
Door Control Unit

EN Installation and Commissioning
Instructions with Terminal Diagram

139930-02

Contents

1	About this document	2
1.1	Product description.....	2
1.2	Related documents.....	2
1.3	Key to symbols.....	3
2	Safety and responsibility	3
2.1	General safety instructions	3
2.2	Product liability	3
3	Installation and assembly.....	4
3.1	Preconditions	4
3.2	Installing the flush-mounted door control unit.....	4
3.3	Fitting the surface-mounted door control unit	6
3.4	Replacing the lock cylinder	7
4	Commissioning	8
4.1	Preconditions	8
4.2	Settings	8
4.3	Description of basic functions.....	8
4.4	Fire detection system (BMA), hazard alert system (GMA), smoke and heat extraction system (RWA).....	8
5	Operation.....	9
5.1	Controlling door control unit TZ 300 with the key switch	9
5.2	Opening doors in emergencies and triggering the alarm	10
5.3	Cancelling alarms	10
5.4	Alarm signal	11
5.5	Removing alarms and system faults.....	11
6	Terminal diagram	12
6.1	Door control units	12
6.2	Key switch.....	14
6.3	Timer	14
7	Appendix.....	15
7.1	Commissioning check list.....	15

1 About this document

These instructions describe the installation and commissioning of the GEZE TZ 300 door control unit.

1.1 Product description

The GEZE door control unit is part of the SecuLogic emergency exit system. It is designed for controlling and monitoring electrically interlocked emergency exit doors. The GEZE door control unit reliably secures doors along emergency exit routes against unauthorized access. At the same time the built-in emergency stop pushbutton allows instant passage in the event of an emergency.

1.2 Related documents

All components are supplied with data sheets containing their technical specifications. These data sheets, as well as further documentation and the detailed installation and commissioning instructions with terminal diagram No. 137351-00, is available on the Internet under www.geze.de/SecuLogic.

1.3 Key to symbols

Warning



In these instructions, warnings are used to warn against material damage and injuries.

- ▶ Always read and observe these warnings.
- ▶ Follow all instructions marked with the warning symbol and the word WARNING.

Warning symbol	Warning	Meaning
	WARNING	Danger for people. Serious or fatal injury can occur if these instructions are not observed.

Further symbols used in these instructions

Important information and technical notes are emphasised to illustrate the correct operation.

Symbol	Meaning
	means "Important note"
	means "Additional information"
	Symbol for a user action. Here you have to take an action. Observe the sequence if there are several action steps.

2 Safety and responsibility

The GEZE door control unit has been designed according to the latest technical standards and acknowledged safety rules and regulations. Dangers can, nevertheless, occur in its installation and use. You must therefore observe the following instructions.

2.1 General safety instructions

- ▶ Installation, commissioning and repairs must be performed only by GEZE-authorized specialists.
- ▶ Use only genuine GEZE parts for repairs.
- ▶ GEZE accepts no liability for damage arising from unauthorized modifications to the installation.
- ▶ Primary building safety measures must be taken by the owner.
- ▶ Cables must be laid according to standards VDE 0100 and VDE 0815.
- ▶ Doors with electrical locks along escape routes should be inspected annually by a specialist. The specialist must issue a certificate verifying the periodic inspection, which the owner must submit to the building inspectorate on request. The inspection can be performed by a GEZE service technician or a GEZE-authorized service provider.
- ▶ In addition, GEZE recommends a monthly inspection of the emergency exit system for visible damage and faults by the owner. Any identified damage or faults must be rectified immediately by a GEZE service technician or a GEZE-authorized service provider.

Intended use

The GEZE door control unit is intended for controlling and monitoring electrically locked emergency exits. Third-party products must be used only after consultation with GEZE.

Improper use

Improper use includes the connection of any products that are not expressly approved by GEZE.

2.2 Product liability

- According to manufacturers' liability for their products as defined in the German product liability act, the information contained herein and in the associated installation instructions and terminal diagrams (product information and intended use, incorrect use, product performance, product maintenance, obligation to inform and obligation to provide instruction) must be observed. Non-observation frees the manufacturer from their liability.
- Installation, function testing and maintenance must be performed only by GEZE-authorized personnel. GEZE accepts no liability for damage arising from unauthorized modifications to the installation.
- A combination with third-party devices invalidates GEZE's warranty. For repair and maintenance, use only original GEZE parts.

3 Installation and assembly



WARNING!

Risk of death through electric shock.

- ▶ Installation must be performed only by GEZE-approved specialist personnel.
- ▶ Check that all cables are voltage-free before installation.

3.1 Preconditions

- Cables are routed according to GEZE cabling diagram
- Miniature circuit-breakers as primary, mains-side disconnectors
- Observation of standards VDE 0100 und VDE 0815 for laying cables
- Tamper-proof cable routing according to VDE 0833 (surface-mounted cables in steel conduit)
- For flush-mounted cabling, flush-mounted sockets (depth 62.5 mm) at a mounting height of 850 mm from upper edge of floor and up to 1200 mm for the emergency button

3.2 Installing the flush-mounted door control unit

These instructions describe the recommended installation of the a flush-mounted door control unit using the TZ 300 SN as an example.

- ▶ Lay mains cable and ribbon cable in the flush-mounted sockets.
- ▶ Connect cable to terminal blocks according to terminal diagram.

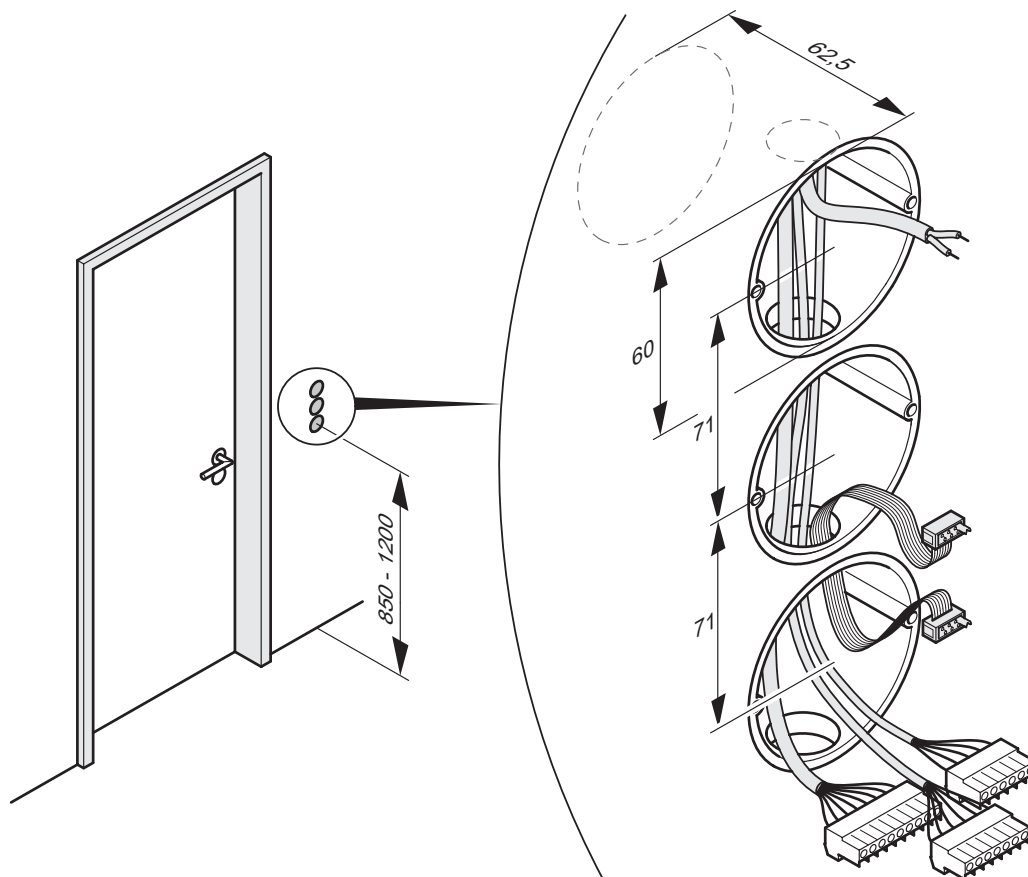

- ▶ Connect and fit the PSU.
- ▶ Connect the door control module with the key switch using the ribbon cable.

- ▶ Fit the terminal blocks to the back of the door control unit.

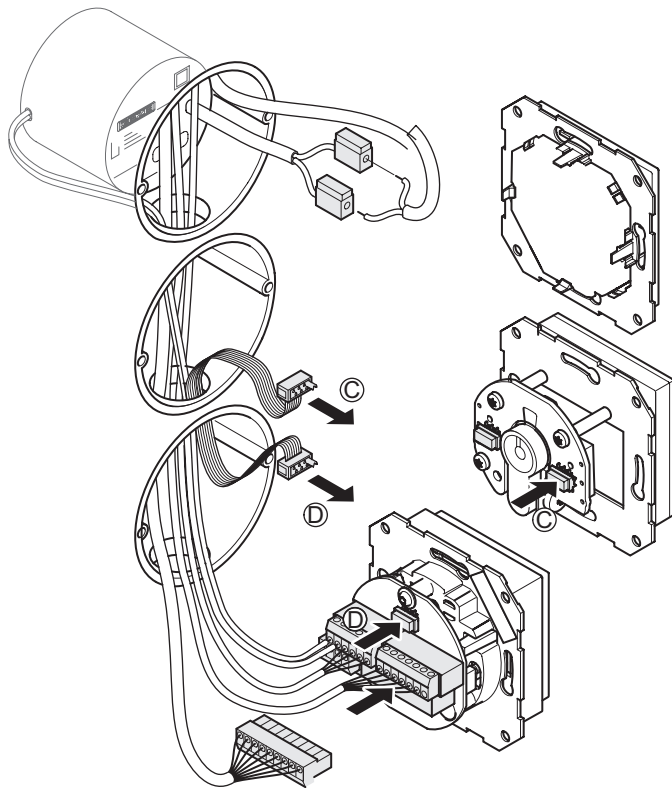

- ▶ Fit the door control unit.
- ▶ Fit the green adhesive frame.

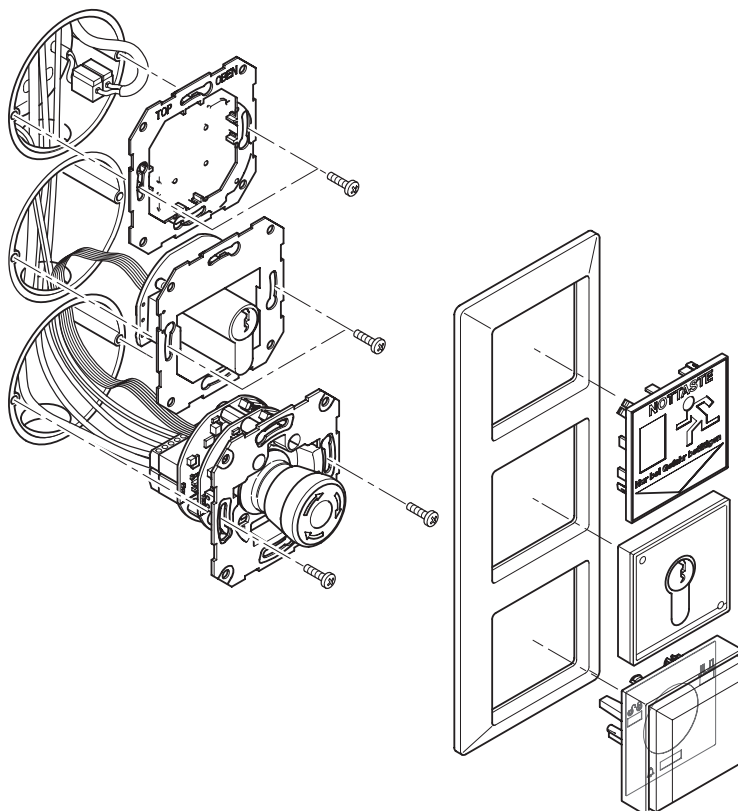

- ▶ Test the unit's function.

3.3 Fitting the surface-mounted door control unit

- ▶ Open the housing.

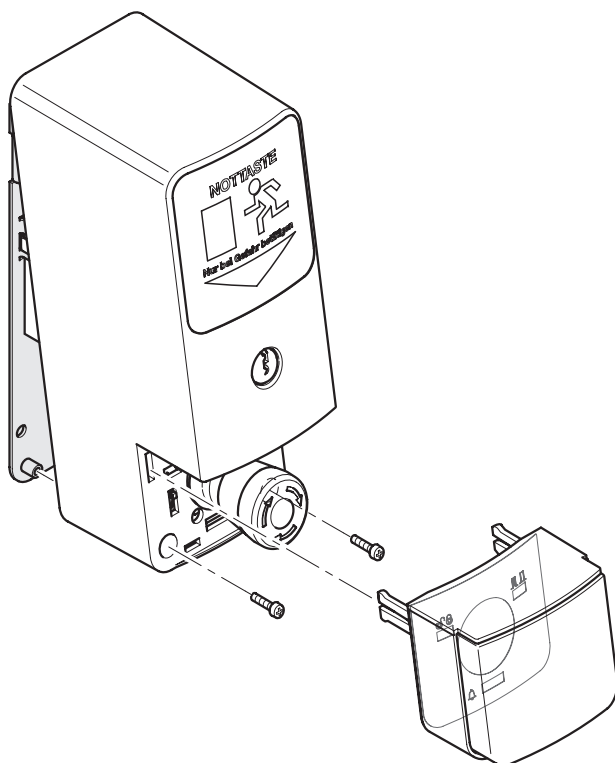

- ▶ Fit the wall-mounting bracket near the door (height of emergency button: 850 mm – 1200 mm from floor surface).

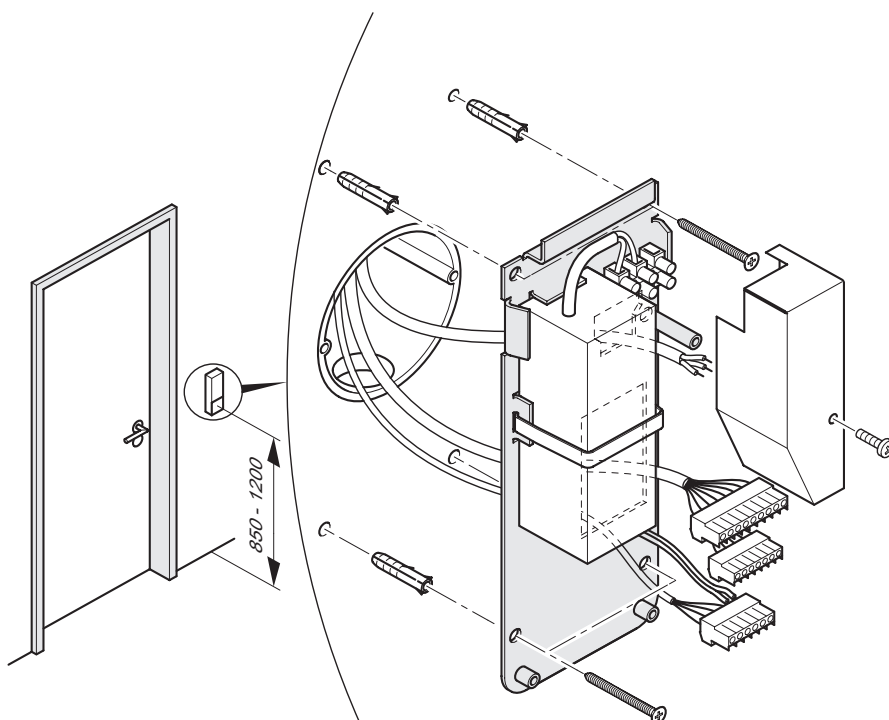

- ▶ Take off the mains connection cover.
- ▶ Connect the 230 V cable to the screw terminals of the PSU and refit the cover.
- ▶ Connect cable to terminal blocks according to terminal diagram.
- ▶ Fit the terminal blocks to the back of the door control unit.
- ▶ Secure loose cables with cable ties.

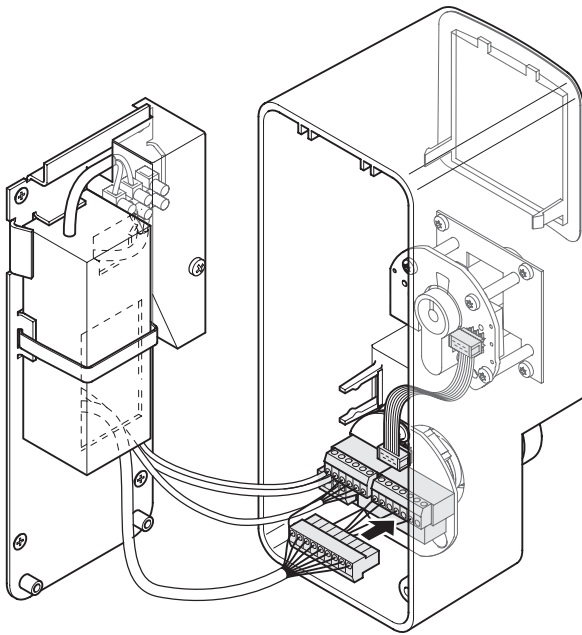

- ▶ Hook in housing and secure with screws.
- ▶ Fit the cover of the emergency button.
- ▶ Test the unit's function.
- ▶ Apply the labels "EMERGENCY" and "Press only in emergency" in the required language on the provided fields on the emergency exit sign. The required adhesive labels are supplied separately in English, French, German and Norwegian.

3.4 Replacing the lock cylinder

- i** The lock cylinder must fulfil the following requirements:
- Profile half-cylinder, 40 mm (30/10)
 - Eight-way adjustable

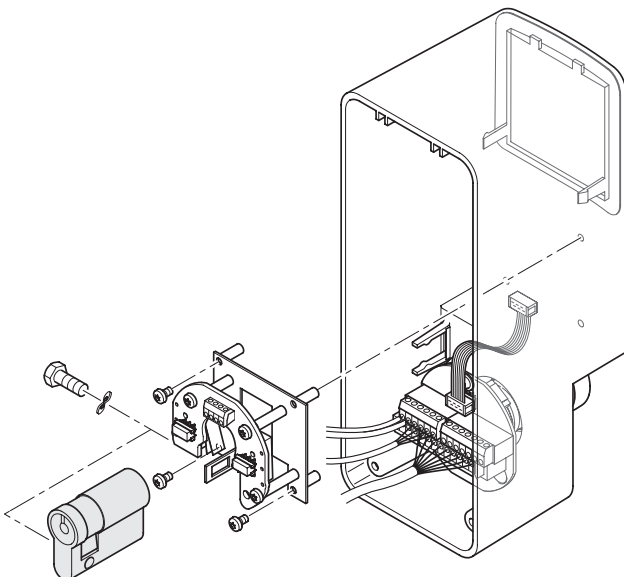

- ▶ When the plant is in operation, disable tamper switch.
 - To do this, turn key to left for ten seconds.
 - Right LED lights up green.
 - Left LED goes out.
 - Tamper alarm function is disabled for two minutes.
- ▶ Take housing off the wall bracket.
- ▶ Unscrew key switch.
- ▶ Release cap screw and remove the lock cylinder.
- ▶ Replace the lock cylinder.
- ▶ Fit a new lock cylinder and secure with cap screw.
- ▶ Reassemble the door control unit in reverse order to disassembly.
- ▶ Test the unit's function.

4 Commissioning

4.1 Preconditions

Doors with electrical locks along escape routes must be taken into operation after the manufacturer has certified their suitability for the intended purpose. In addition, the correct installation and correct function of the electrical lock must be verified by a specialist.

4.2 Settings

No settings can be made or changed on the door control unit. All values, such as temporary unlocking, cancelling, pre-alarm, etc. are permanently set.

4.3 Description of basic functions

4.3.1 Temporary unlocking (KZF)

Temporary unlocking releases the emergency door protection for a limited time. During this time, access through the door is possible without triggering an alarm. It is activated with the built-in key switch or an external actuator connected to the Temporary Unlocking input.

The temporary unlocking duration is about 20 seconds. This value can not be changed.

4.3.2 Cancellation of temporary unlocking

When temporary unlocking is active, the door locks prematurely when it is closed before the temporary unlocking time has expired. This prevents unauthorized access through the door after an authorized person has gone through.

4.3.3 Pre-alarm

If the door is passed through after the temporary unlocking time has expired, an audible signal is issued to warn the user that the temporary unlocking time has expired. The pre-alarm duration is **60 seconds**. If the door is closed while a pre-alarm is active, the door is locked again automatically and the pre-alarm is reset.

4.3.4 Door alarm

If the pre-alarm time is exceeded, the door alarm is triggered. This must then be reset with the built-in key switch or with a new temporary unlocking command. If the door is closed while the door alarm is active, it locks and can be unlocked again only after the alarm has been reset (except when the emergency button is pressed or emergency unlocking is triggered). The door alarm is also triggered when the door is opened forcefully.

4.4 Fire detection system (BMA), hazard alert system (GMA), smoke and heat extraction system (RWA)

4.4.1 Alarm triggers

If the BMA, GMA or RWA signal of a door control unit is applied, it is unlocked and a local alarm is triggered (audible through built-in buzzer and visual through built-in LED). The system remains unlocked as long as the signal is applied and until the alarm has been reset. The alarm is triggered through a floating NC contact.

4.4.2 Resetting/acknowledging the alarm

When the BMA signal is cancelled, the alarm is automatically reset after 60 seconds. The visual and audible signal at the TZ 300 goes out and the door control unit locks the door.

The system can be reset before the 60 seconds have expired with the built-in key switch of the TZ 300.

5 Operation

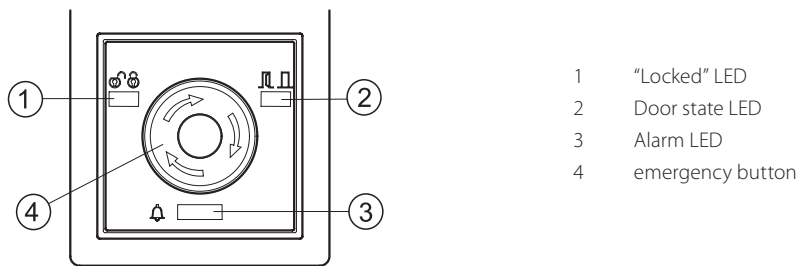

No.	Indicator	Colour	Meaning
1		Red	Locked
		Green	Unlocked
		Green flashing (every second)	Temporary unlocking
2		Red	Door closed
		Green	Door open
3		Yellow	Alarm
		Yellow flashing (every second)	Pre-alarm
		Yellow flashing	Fault

5.1 Controlling door control unit TZ 300 with the key switch

Unlocking the door

When the system is unlocked, the locking elements are disabled and the door can be opened.

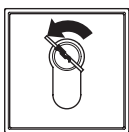

- ▶ Turn the key to the left and hold it for about one second.
- LED 1 lights up green. The door is unlocked.

Locking the door

When the system is unlocked, the locking elements are enabled and the door can not be opened.



- ▶ Turn the key to the right.
- LEDs 1 and 2 light up red. The door is locked.

Unlocking the door temporarily (temporary unlocking = 20 seconds)

With the temporary unlocking function, the door can be unlocked with the key switch for 20 seconds. When this time has expired, the door is locked again.

- If the door is not closed after temporary unlocking, a pre-alarm is issued.
- If the door is closed after the temporary unlocking time has expired, the door is locked again.
- If the temporary unlocking function is triggered again while the function is still active, the temporary unlocking period starts again (is retriggered).



- ▶ Turn the key to the right.
- LED 1 flashes green.

5.2 Opening doors in emergencies and triggering the alarm

When the emergency button is pressed the door's locking elements are de-energized and the door can be opened (direct unlocking).

- ▶ Press the emergency button.
- LED 1 lights up green and LED 3 lights up yellow. The door is unlocked.
- The alarm is triggered.

5.3 Cancelling alarms

Alarms of the door control unit remain active until their cause has been eliminated and the alarm is acknowledged at the door control unit. (Exception: emergency unlocking through BMA,GMA or RWA, after which the alarm is automatically reset after 60 seconds; see section 4.4.3.)

5.3.1 Resetting emergency button

When the emergency has passed, the emergency button must be reset.

- ▶ Remove emergency button cover.
- ▶ Turn the emergency button to the right.
- The emergency button returns to its normal state.
- ▶ Refit the cover.
- ▶ Acknowledge the alarm.

5.3.2 Acknowledge alarm



Precondition:
The alarm cause has been eliminated.

To acknowledge the alarm and lock the door



- ▶ Turn the key to the right.

To acknowledge the alarm and unlock the door



- ▶ Turn the key to the left.

The door alarm can also be acknowledged through the **temporary unlocking** input.



A tamper alarm can be acknowledged only 30 seconds after the alarm cause has been eliminated. For the duration of the tamper alarm the TZ 300 remains locked. It can, however, be unlocked with the emergency button.

If the alarm can not be acknowledged with the key switch, a new alarm may be active. If, for example, the cover was not refitted after resetting the emergency button, a tamper alarm is triggered when emergency unlocking is acknowledged, and the door control unit locks the door. This is indicated by a change in the sound of the audible signal.

5.4 Alarm signal

Misuse of the system and emergency situations are indicated by a built-in buzzer and yellow alarm LED 3.

Alarm	Alarm LED	Alarm bell
Pre-alarm	Yellow flashing light (1 s on, 1 s off)	Acoustic signal, 2 beeps
Door alarm	Yellow continuous light	Acoustic signal, 2 seconds continuous
Tamper alarm	Yellow continuous light	Acoustic signal, 4 beeps
Alarm -Unlocking through emergency button-Trig- gering through BMA/GMA	Yellow continuous light	Acoustic signal, 4 seconds continuous
System fault	Yellow flashing light at 2 second interval	No acoustic signal

5.5 Removing alarms and system faults

Alarm state	Cause of alarm	Elimination of alarm cause
Pre-alarm	Door not closed after unlocking period has expired. No Closed signal	▶ Close door.
		▶ Unlocking the door
Door alarm	No Closed signal	▶ Close door. ▶ Check door contact.
	No Locked signal	▶ Check locking element.
Tamper alarm	Tamper switch of door control unit not closed (on UP only).	▶ Close contact. ▶ Fit cover. ▶ After duration of tamper alarm, acknowledge alarm.
	Key switch tamper switch not closed.	
Alarm	Emergency button of TZ 300 pressed (direct unlocking).	▶ Reset door control unit emergency button.
	Fuse in TST300 blown	▶ Check fuse. ▶ Replace fuse.
	Emergency unlocking through connected BMA, GMA or RWA.	▶ Check BMA, GMA or RWA and switch off emergency unlocking signal. ▶ Check input of affected door control unit.
	2K resistor between terminals 2 and 10 not set and no BMA, GMA or RWA connected.	▶ Fit a 2K resistor between terminals 2 and 10.
	Locking element connected with reversed polarity. Emergency button LED goes on and off. Other LEDs remain off. (With PSUs NET220 und NT19.2-24. With larger PSUs the fuse blows.)	▶ Immediately isolate from the power supply and connect correctly.
	Locking element not connected.	▶ Connect locking element.
	Jumper on FTÖ331U was not removed. FTÖ332 is connected without RP220.	▶ Remove jumper on FTÖ331. ▶ Check locking element supply line for short-circuit.
	Short-circuit in the supply line of the locking element.	▶ Connect FTÖ332 with RP220. ▶ Press emergency button. ▶ Release (pull out) emergency button.
	Controller defective	▶ Replace door control unit.

6 Terminal diagram

6.1 Door control units

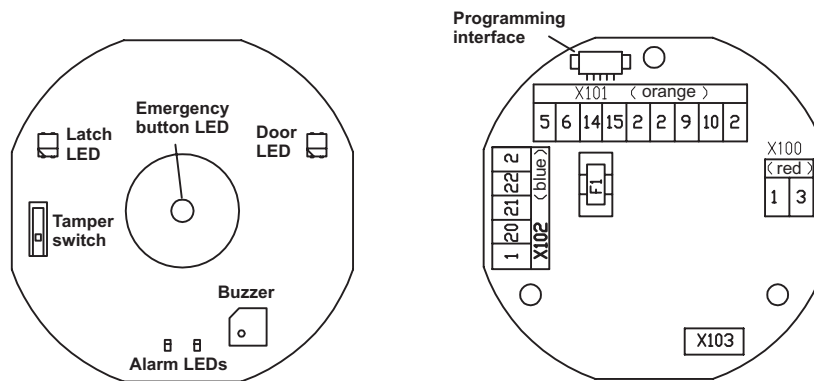

6.1.1 Door control unit TZ 300 (terminals, fuses)

Fuse

Name	Value	Meaning
F1	1.5 A, SMF 125 V, quick-acting	24 V external

Terminal assignment

Max. cable cross-section for screw and plug-in terminals: 1 mm²

		Terminal function		
X103	Blade terminal for GEZE key switch			
X100	Red terminal field	1	Supply GND	
		3	24 V DC supply	
X101	Orange terminal field	5	Locking element, +, 24 V DC	
		6	Locking element, -, GND	
		14	Door Locked feedback	
		15	Door Closed feedback	
		2	24 V DC	
		2	24 V DC	
		9	Brief Unlocking input	
		10	Emergency Unlocking input	
		2	24 V DC	
X102	Blue terminal field	2	24 V DC	
		22	NO, alarm output	Max. 1 A, 24 V DC 
		21	Com, alarm output	
		20	NC, alarm output	
		1	GND	

6.1.2 Notes about the terminal diagram

The notes apply for the following terminal diagram of the various versions of the TZ 300.

- 1) Building mains fuse.
- 2) Spatially separate primary and secondary side. With the TZ 320 the PSU is fitted outside the door control unit.
- 3) TZ 300 SN UP: Protection class II, PE (protective earth) conductor is not connected.
TZ 300 SN AP: Protection class I with PE conductor testing according to VDE0100.
- 4) 2K resistor set by default. In delivery state the 2K resistor is fitted.
When connecting a BMA, GMA or RWA, remove the resistor and connect it in series with the NC contact of the BMA, GMA or RWA (see plan "Emergency unlocking through BMA, GMA or RWA").
- 5) Contact closed when door closed.
- 6) When a GEZE alarm bell or siren is fitted, a jumper must be set.

6.1.3 Door control unit TZ 300 S, TZ 300 SN

S = with GEZE key switch
 SN = with GEZE key switch and PSU

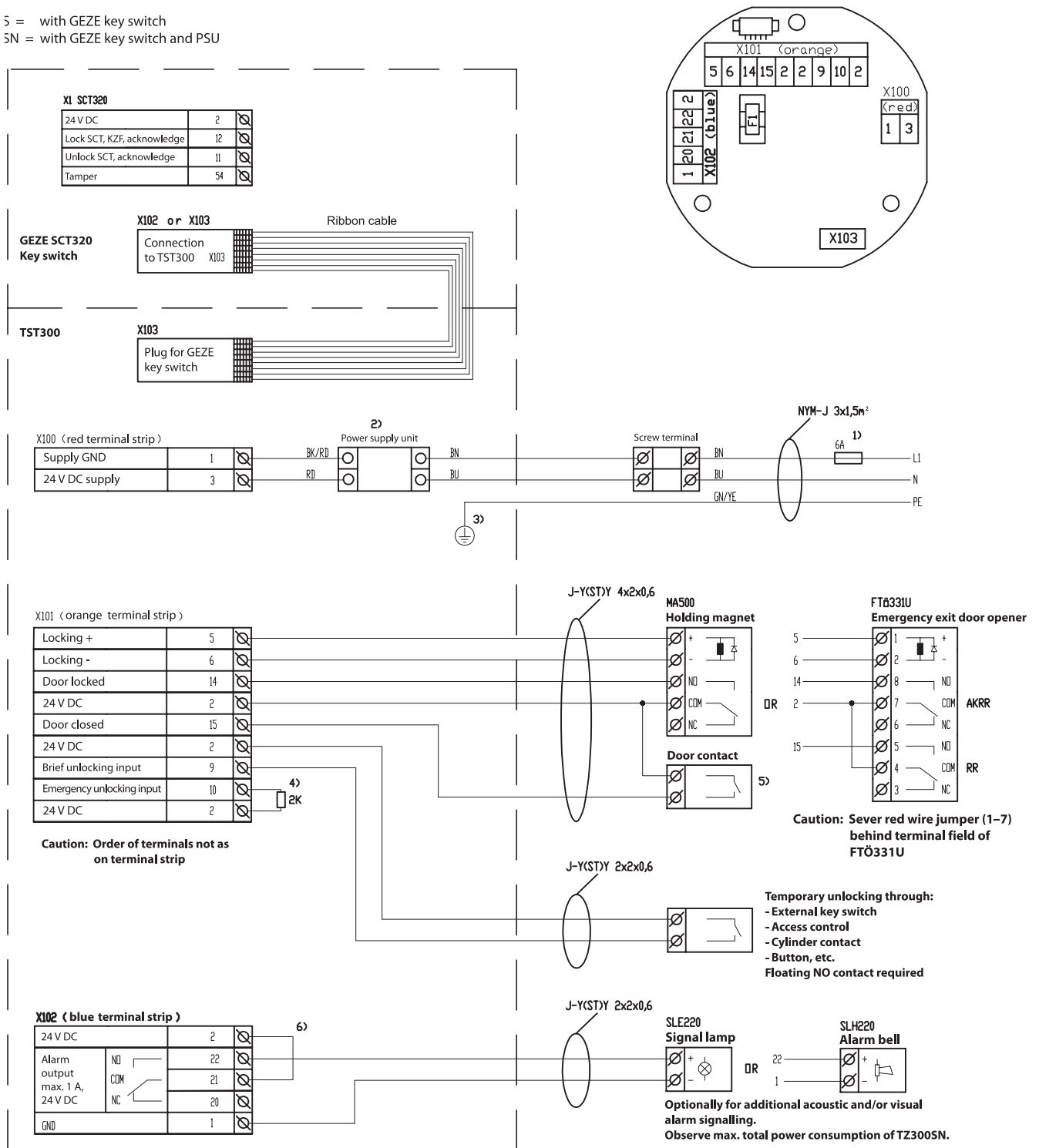

6.1.4 Emergency unlocking through BMA, GMA or RWA

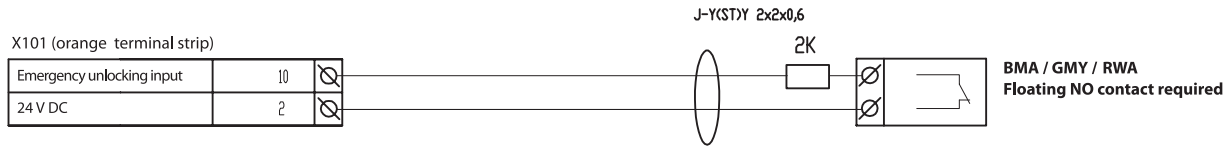

If a BMA, GMA or RWA system is connected, the 2K resistor fitted to terminals 2 and 10 of the TZ 300 must be removed and connected in series with the NC contact of the triggering device. The alarm automatically resets after 60 seconds when its cause has been removed (contact closed again).

6.2 Key switch

6.2.1 Key switch SCT221/SCT to temporary unlocking

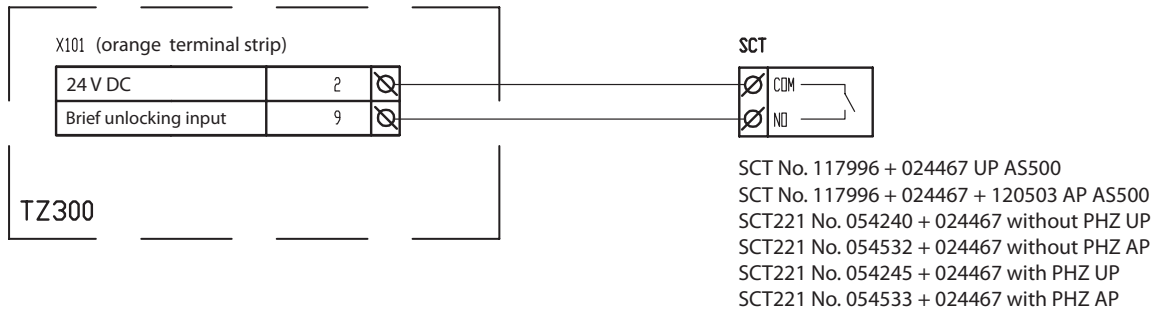

6.2.2 Key switch SCT320 for external control unlocking, locking, temporary unlocking and acknowledging alarms

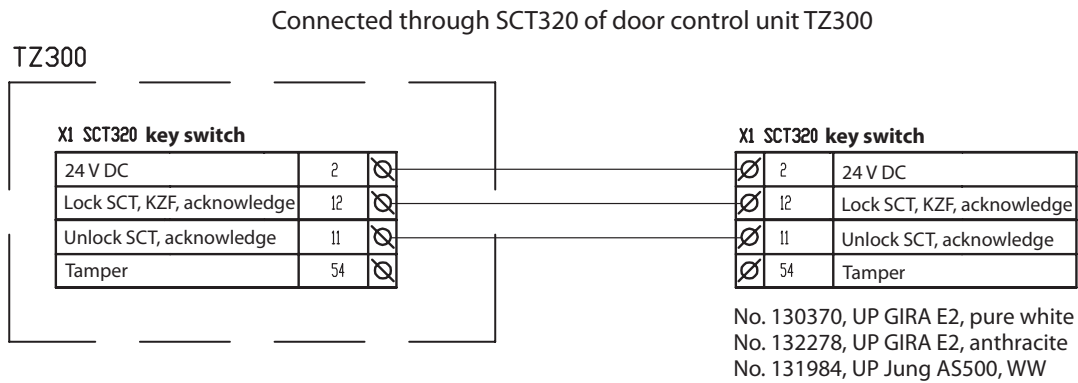

6.3 Timer

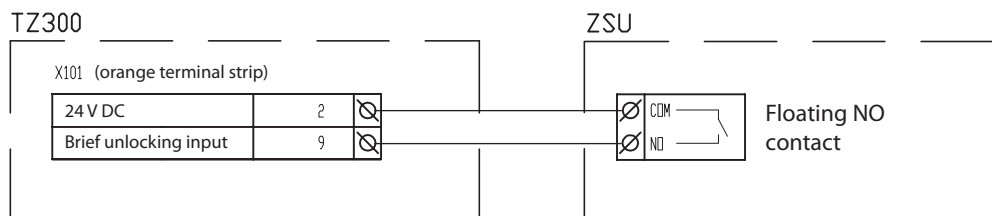

The door control unit is temporarily unlocked for the duration of the contact.

7 Appendix

7.1 Commissioning check list

	Yes	No	Not fitted
Power supply OK			
Upper edge of all emergency buttons between 850 and 1200 mm from floor surface			
All emergency button labels applied			
Cables laid according to DIN VDE 0833, tamper-protected			
All screws of magnet mounting tightened			
Rubber buffers on screws of magnetic disc OK			
Magnet surfaces cleaned			
Door passage lights at least 2000 mm			
Emergency door opener fitted correctly and tamper-protected			
All cables connected, exposed cables insulated			
Emergency button illumination working			
"Emergency button" function OK			
Tamper switches working correctly			
Unlocking through key switch is working correctly			
Locking through key switch is working correctly			
Feedback from magnet and/or door opener working correctly			
Additional door contacts working correctly			
Door Leaf Open/Closed LED working correctly			
Door Locked/Unlocked LED working correctly			
Alarm/Fault LED working correctly			
2K resistor correctly set if BMA, GMA or RWA connected			
Magnets working; door openers are locking			
All access possibilities OK (access control, etc.)			
Emergency exit doors OK			
External key switch OK			
External alarm generator/alarm generator combination working correctly			
Uninterruptible power supply working correctly			

Germany
GEZE GmbH
Niederlassung Süd-West
Tel. +49 (0) 7152 203 594
E-Mail: leonberg.de@geze.com

GEZE GmbH
Niederlassung Süd-Ost
Tel. +49 (0) 7152 203 6440
E-Mail: muenchen.de@geze.com

GEZE GmbH
Niederlassung Ost
Tel. +49 (0) 7152 203 6840
E-Mail: berlin.de@geze.com

GEZE GmbH
Niederlassung Mitte/Luxemburg
Tel. +49 (0) 7152 203 6888
E-Mail: frankfurt.de@geze.com

GEZE GmbH
Niederlassung West
Tel. +49 (0) 7152 203 6770
E-Mail: duesseldorf.de@geze.com

GEZE GmbH
Niederlassung Nord
Tel. +49 (0) 7152 203 6600
E-Mail: hamburg.de@geze.com

GEZE Service GmbH
Tel. +49 (0) 1802 923392
E-Mail: service-info.de@geze.com

GEZE GmbH
Reinhold-Vöster-Straße 21–29
71229 Leonberg
Germany

Austria
GEZE Austria
E-Mail: austria.at@geze.com
www.geze.at

Baltic States –
Lithuania / Latvia / Estonia
E-Mail: baltic-states@geze.com

Benelux
GEZE Benelux B.V.
E-Mail: benelux.nl@geze.com
www.geze.be
www.geze.nl

Bulgaria
GEZE Bulgaria - Trade
E-Mail: office-bulgaria@geze.com
www.geze.bg

China
GEZE Industries (Tianjin) Co., Ltd.
E-Mail: chinasales@geze.com.cn
www.geze.com.cn

GEZE Industries (Tianjin) Co., Ltd.
Branch Office Shanghai
E-Mail: chinasales@geze.com.cn
www.geze.com.cn

GEZE Industries (Tianjin) Co., Ltd.
Branch Office Guangzhou
E-Mail: chinasales@geze.com.cn
www.geze.com.cn

GEZE Industries (Tianjin) Co., Ltd.
Branch Office Beijing
E-Mail: chinasales@geze.com.cn
www.geze.com.cn

France
GEZE France S.A.R.L.
E-Mail: france.fr@geze.com
www.geze.fr

Tel.: 0049 7152 203 0
Fax.: 0049 7152 203 310
www.geze.com

Hungary
GEZE Hungary Kft.
E-Mail: office-hungary@geze.com
www.geze.hu

Iberia
GEZE Iberia S.R.L.
E-Mail: info.es@geze.com
www.geze.es

India
GEZE India Private Ltd.
E-Mail: office-india@geze.com
www.geze.in

Italy
GEZE Italia S.r.l. Unipersonale
E-Mail: italia.it@geze.com
www.geze.it

GEZE Engineering Roma S.r.l.
E-Mail: italia.it@geze.com
www.geze.it

Korea
GEZE Korea Ltd.
E-Mail: info.kr@geze.com
www.geze.com

Poland
GEZE Polska Sp.z o.o.
E-Mail: geze.pl@geze.com
www.geze.pl

Romania
GEZE Romania S.R.L.
E-Mail: office-romania@geze.com
www.geze.ro

Russia
OOO GEZE RUS
E-Mail: office-russia@geze.com
www.geze.ru

Scandinavia – Sweden
GEZE Scandinavia AB
E-Mail: sverige.se@geze.com
www.geze.se

Scandinavia – Norway
GEZE Scandinavia AB avd. Norge
E-Mail: norge.se@geze.com
www.geze.no

Scandinavia – Denmark
GEZE Danmark
E-Mail: danmark.se@geze.com
www.geze.dk

Singapore
GEZE (Asia Pacific) Pte, Ltd.
E-Mail: gezesea@geze.com.sg
www.geze.com

South Africa
GEZE South Africa (Pty) Ltd.
E-Mail: info@gezesa.co.za
www.geze.co.za

Switzerland
GEZE Schweiz AG
E-Mail: schweiz.ch@geze.com
www.geze.ch

Turkey
GEZE Kapı ve Pencere Sistemleri
E-Mail: office-turkey@geze.com
www.geze.com

Ukraine
LLC GEZE Ukraine
E-Mail: office-ukraine@geze.com
www.geze.ua

United Arab Emirates/GCC
GEZE Middle East
E-Mail: gezeme@geze.com
www.geze.ae

United Kingdom
GEZE UK Ltd.
E-Mail: info.uk@geze.com
www.geze.com

